

FITTING INSTRUCTION

Clamp mark in acc. with		Cables joining
ISO	PN	
1	L	Left directional lights
2	+	Rear fog lights
3	31	Ground
4	R	Right directional lights
5	58R	Right side parking lights
6	54	Stoplights
7	58L	Left side parking lights

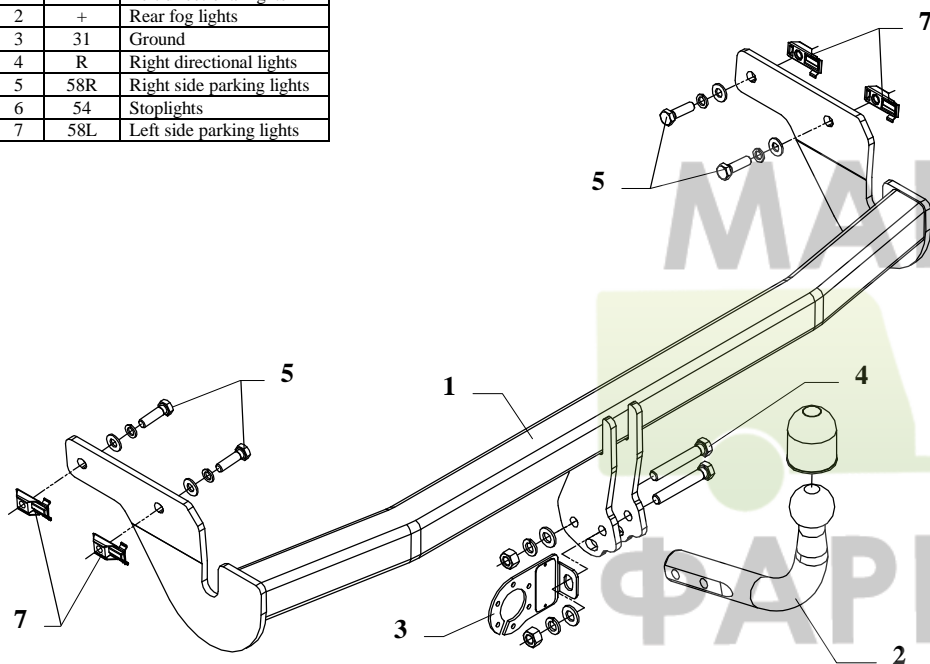

This towbar is designed to assembly in following car:
PEUGEOT 207, produced since 2006, catalogue number **F30** and is prepared to tow trailers max total weight **1150 kg** and max vertical load **46 kg**.

Foreword

Thank you for buying our product. This towbar is design according to rules of safety traffic regulations and their reliability has been confirmed in many tests. Reliability of towbar also depends on correct assembly and correct exploitation. For this reasons we kindly ask to read carefully this instruction and apply to hints.

The towbar should be install in places described by a car producer.

The instruction of the assembly

1. For the purpose of installings of the towbar one ought to disassemble the bumper.
2. In existing holes in left and right chassis member put per two special nuts (Caget Nut, 44x17mm).
3. Put the main bar of the towbar (pos. 1) to chassis members in this way, so towbar holes agree to nuts (previously inserted) and fix all using bolts M10x35mm (pos. 5) from accessories.
4. Cut out fragment of the bumper (in axis of symmetry):
 - tow-ball for two bolts: 50mm width., 20mm length,
 - take off ball, „automat”: 80mm width., 40mm length.
5. Install the bumper.
6. Tighten all bolts according to the torque shown in the table.
7. Fix tow-ball (pos. 2) and socket plate (pos. 3) using bolts M12x75mm (pos. 4) from the towbar accessories.
8. Connect electric wires of 7-poles socket according to the instruction of the car. (Recommend to make at authorized service station).
9. Complete paint layer damaged during installation.

Torque settings for nuts and bolts (8,8):	
M 8 - 25 Nm	M 10 - 55 Nm
M 12 - 85 Nm	M 14 - 135 Nm









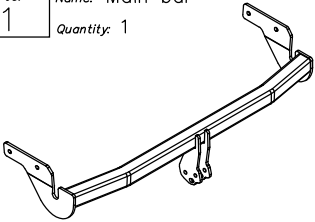
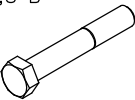

NOTE

After install the towbar you should get adequate note in registration book (at authorised service station).The car should be equipped with:

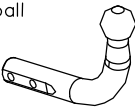
- Indicators
- Tow mirrors

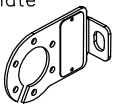
After 1000km check all bolts and nuts. The ball of towbar must be always kept clear and conserve with a grease.

Towbar accessories:

Pos. 1 Name: Main bar Quantity: 1 	Pos. 4 Name: Bolt 8,8 B Quantity: 2 Dim.: M12x75mm 	Pos. 8 Name: Plain washer Quantity: 2 Dim.: Ø 13 mm 
	Pos. 5 Name: Bolt 8,8 B Quantity: 4 Dim.: M10x35mm 	Pos. 9 Name: Plain washer Quantity: 4 Dim.: Ø 10,5 mm 
Pos. 2 Name: Tow ball Quantity: 1 	Pos. 6 Name: Nut 8 B Quantity: 2 Dim.: M12 	Pos. 10 Name: Spring washer Quantity: 2 Dim.: Ø 12,2 mm 
Pos. 3 Name: Socket plate Quantity: 1 	Pos. 7 Name: Capet nut Quantity: 4 Dim.: M10 	Pos. 11 Name: Spring washer Quantity: 4 Dim.: Ø 10,2 mm 
	Pos. 12 Name: Ball cover Quantity: 1 	



PPUH AUTO-HAK S.J.

Produkcja Haków Holowniczych
Henryk & Zbigniew Nejman
76-200 SŁUPSK ul. Słoneczna 16K
tel/fax (059) 8-414-414; 8-414-413
E-mail: office@autohak.com.pl
www. autohak.com.pl

Towing hitch (without electrical set)

Class: **A50-X** Cat. no. **F30**

Designed for:

Manufacturer: **PEUGEOT**

Model: **207**

produced since 2006

Technical data:

D-value: 6,74 kN

maximum trailer weight: **1150 kg**

maximum vertical cup load: **46 kg**

Approval number according to Directive 94/20/EC: **e20*94/20*0122*00**

Foreword

This towbar is designed according to rules of safety traffic regulations. The towing hitch is a safety component and must be installed only by qualified personnel. Any alteration or conversion to the towinh hitch is prohibited and would lead to cancellation of design certification. Remove insulating compound and underseal from vehicle (if present) in the area of the matting surfaces of the towing hitch.

The vehicle manufacturer's specifications regarding trailer load and max. vertical cup load are decisive for driving, and values for the towing hitch must not be exceeded.

D-value formula:

$$\frac{\text{Max trailer weight [kg]} \times \text{Max vehicle weight [kg]}}{\text{Max trailer weight [kg]} + \text{Max vehicle weight [kg]}} \times \frac{9,81}{1000} = D \text{ [kN]}$$